

Solar / Battery Kit: 100 Watt / 140 Ah

SOLAR CENTRAL ENHANCED KIT: M75-SLR14-000C



SOLAR/BATTERY KIT FOR IQ SERIES RADAR SPEED SIGNS

TraffiCalm® solar/battery kits are specifically designed to be used on iQ Series Radar Speed Signs and provide year-round operation of the system. We have a multitude of solar/battery kits and will make sure you have the right sized system for your particular location using our sophisticated solar calculator that takes into account the amount of sunlight (insolation), temperature, and cloudy days experienced by month, as well as the power draw of the particular model of Radar Speed Sign chosen.

FEATURES

Complete Kit

Includes the solar panel, panel rack, solar controller, battery box and heavy-duty mounting bracket, batteries, and conduit-enclosed wiring.

Easy Installation

No trenching required for cables. Utilizes industry standard hardware and mounting techniques. Consistent connectors and fasteners compatible with all TraffiCalm® Radar Speed Signs.

Environmentally Friendly

Utilizing solar energy combined with the low-power draw of Light Emitting Diodes (LEDs) in TraffiCalm® Radar Speed Signs, these solar kits are the environmental choice for our planet, while helping make our roadways safer.

3-Year Warranty

3-year limited warranty on the solar kit, with 1 year on the batteries.

Made in the USA

TraffiCalm® Solar/battery kits are manufactured in the USA in an ISO 9001:2015 certified facility. In addition we provide you unlimited technical phone support for the life of the unit. Build America/Buy America Compliant.

TRAFFICCALM.COM



SPECIFICATIONS

Physical Descriptions

Mounting: Universal bracket accommodates most industry standard round or square posts of suitable load rating

NEMA 3R enclosure

All electronics potted for weatherproofness

Stainless fasteners used for corrosion resistance

Battery Box Dimensions: 35.5" h x 11" w x 8.2" d
(90.17 cm x 27.94 cm x 20.83 cm)

Solar Panel Dimensions: 51.18" l x 20.79" w x 1.38" d
(130 cm x 52.81 cm x 3.51 cm)

Total System Weight: 154 lbs (69.85 kg), includes qty 4 - 35Ah batteries, battery box w/ contents, solar panel, and solar panel rack

Construction

1/16" (.06, 1.58mm) thick aluminum Weatherproof NEMA 3R battery housing

Standard, heavy-duty mounting brackets

Provisions for locking in place are provided with key included

Replacement keys available upon request

Standard powder coat green color polyester finish (additional colors optional)

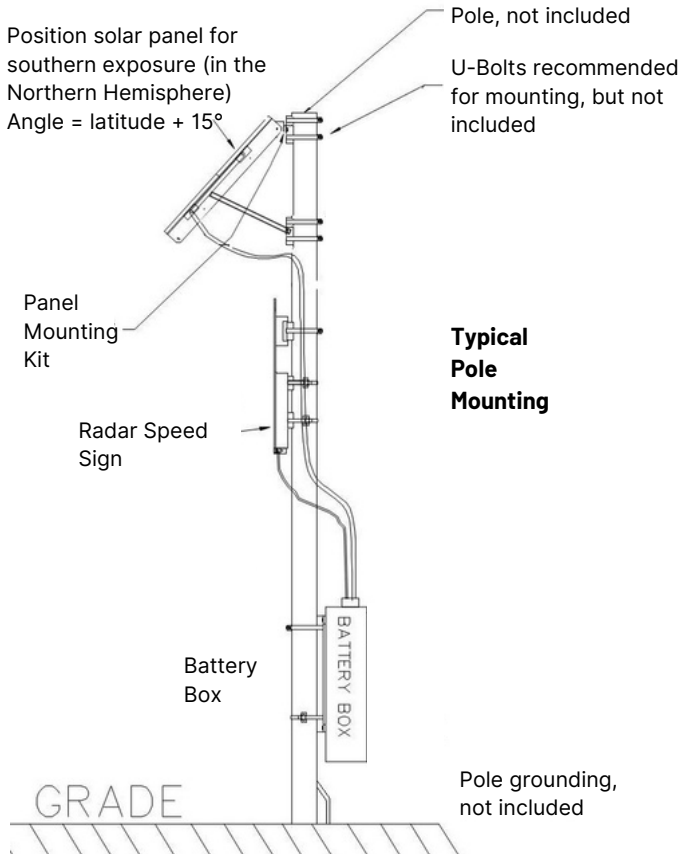

Solar Panel Power Specs

Maximum Power (PMax): 100W
Voltage at PMax (Vmp): 17.2V
Current at PMax (Imp): 4.94A

Open Circuit Voltage (Voc): 21.6V
Short-Circuit Current (Isc): 5.5A

Temp. Coefficient of Voc: $-(80 \pm 10) \text{mV}/^\circ\text{C}$
Temp. Coefficient of Isc: $(0.065 \pm 0.015) \%/^\circ\text{C}$
Temp. Coefficient of power: $-(0.5 \pm 0.05) \%/^\circ\text{C}$

NOCT (Air 20°C; Sun 0.8kW/m² wind 1m/s): 47±2°C
Operating Temperature: -40°F to +85°F (-40°C to +29.44°C)

Maximum system voltage: 60VDC, 1500 watts

Power tolerance: ± 5%

Battery Specs

M75-SLR14-000C includes qty 4 batteries

12V AGM valve regulated, spill proof, high energy density, DOT approved for transport. Nominal Voltage: 12V (6Cells). Nominal Capacity: 20-hr. (1.75A to 10.50V): 35Ah

Approx. Weight: 24.7 lbs each

Energy Density: 1.70 W-h/iñ

Internal Resistance: 8 milliohms

Max Discharge Current (7 Min.): 105.0 amperes

Operating Temperature: Charge: -4°F to 122°F (-20° C to 50° C),
Discharge: -40°F to 140°F (-40° C to 60° C)

Dimensions: 7.72" l x 5.14" w x 6.22" h (19.61 cm x 13.06 cm x 15.8 cm)

Warranty

3 year warranty, 1 year on batteries

Unlimited technical support

