

100 Watt Solar Panel Kit

SOLAR KIT: M75-SLRPN-100W



100 WATT SOLAR PANEL KIT

TraffiCalm® Flashing Sign Systems solar kits are specifically designed to provide extensive flexibility in all their applications and provide year-round operation of the system. We have a multitude of solar kits and will make sure you have the right-sized system for your particular location using our sophisticated solar calculator that takes into account the amount of sunlight (insolation), temperature, and cloudy days experienced by month, as well as the power draw of the particular model of Flashing Sign System chosen.

FEATURES

Complete Kit

Includes the solar panel, panel rack, and heavy-duty mounting bracket.

Easy Installation

No trenching required for cables. Utilizes industry standard hardware and mounting techniques. Consistent connectors and fasteners compatible with all TrafficCalm® Flashing Sign Systems.

Environmentally Friendly

Utilizing solar energy combined with the low-power draw of Light Emitting Diodes (LEDs) in TrafficCalm® Flashing Sign Systems, these solar kits are the environmental choice for our planet, while helping make our roadways safer.

5-Year Warranty

5-year limited warranty on the solar kit.

Made in the USA

TraffiCalm® Solar kits are manufactured in the USA in an ISO 9001:2015 certified facility. In addition, we provide you unlimited technical phone support for the life of the unit. Build America/Buy America Compliant.

TRAFFICALM.COM



SPECIFICATIONS

Physical Descriptions

SOLAR PANEL:

51.18" l x 20.79" w x 1.38" d (130 cm x 52.81 cm x 3.51 cm)

Heavy-duty anodized frame

High transparent low-iron, tempered glass

BRACKET:

90MPH (144KPH) Wind Load Rating

1.1kN/M2 Snow Load Rating

Side of Pole/Wall Mount (U-bolts required)

Construction

High efficiency 100 Watt Polycrystalline panel mounted to a high-wind resistant panel bracket, and connected via an easy-to-install, outdoor-rated cable harness.

Perfectly matched with a Maximum Power Point Tracking (MPPT) charging circuit, the solar panel will make the most of what day light is available.

Solar Panel Power Specs

Maximum Power (PMax): 100W

Voltage at PMax (Vmp): 17.2V

Current at PMax (Imp): 4.94A

Open Circuit Voltage (Voc): 21.6V

Short-Circuit Current (Isc): 5.5A

Temp. Coefficient of Voc: $-(80 \pm 10) \text{mV}/^\circ\text{C}$

Temp. Coefficient of Isc: $(0.065 \pm 0.015) \%/^\circ\text{C}$

Temp. Coefficient of power: $-(0.5 \pm 0.05) \%/^\circ\text{C}$

NOCT (Air 20°C; Sun 0.8kW/m2 wind 1m/s): $47 \pm 2^\circ\text{C}$

Operating Temperature: -40°F to $+85^\circ\text{C}$ (-40°C to $+29.44^\circ\text{C}$)

Maximum system voltage: 600V DC

Power tolerance: $\pm 5\%$

Warranty and Service

5-year warranty

Unlimited tech support from US based factory technicians

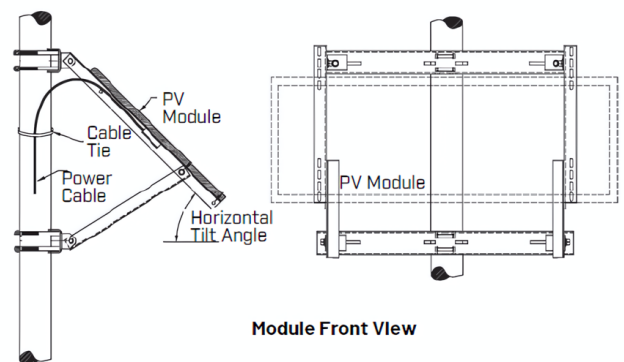
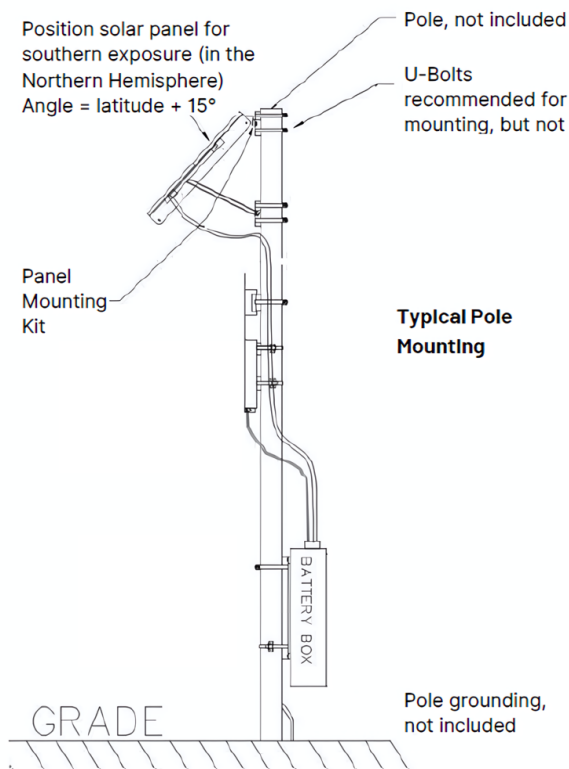

*Solar panel sizes subject to change without notice.