



iQ900™

LED Driver Feedback Signs

Installation Instructions 029-04482-0000 Rev E

August 2019

Model: iQ900 Portable **Portable Driver Feedback Sign**

Table of Contents

Revision Block	2
1 About This Manual	3
1.1 Purpose of Manual	3
1.2 Manual Conventions	3
1.3 Related Document	3
1.4 Manual Organization	3
2 Safety Information	4
2.1 Intended Use	4
2.2 Technical Support.....	4
2.3 Safety Messages.....	4
2.3.1 Safety Message Format	4
2.4 Safety Messages Contained in This Manual	4
2.5 Safety Considerations	6
2.5.1 Personal Safety Equipment and Clothing.....	6
2.5.2 Electrical Shock	6
2.5.3 RF Exposure	6
2.5.4 Battery Safety.....	6
2.5.5 Mechanical Safety.....	7
2.5.6 Functional Safety	8
3 Description 8	
3.1 9” DFB Sign Specifications	10
3.2 9” DFB Sign Power Options.....	10
4 Installation Requirements	10
4.1 Equipment Requirements.....	10
4.2 Requirements for SafetyCalm™ Software.....	11
5 Pre-Installation	11
5.1 Site Survey.....	11
5.2 Pole Selection	11
5.3 Mounting Brackets.....	12
5.4 Sign Test Procedure	12
5.4.1 Expected Sign Behavior.....	12
6 Installation	12
6.1 Sign Installation	13
6.1.1 Aiming the Sign	13
6.1.2 Sign Radar Operation.....	13
6.1.3 Radar Properties.....	13
6.1.4 Measurement Angle	14
6.1.5 Powering and Charging Instructions	14
6.1.6 External Beacon Connection.....	15
6.1.9 NiMH Battery Storage.....	16
7 Troubleshooting	17
7.1 General Troubleshooting.....	17
Warranty	20
Appendix A: 9” DFB Drawing	21
Appendix B: Recommended External Beacon Wiring	22

NOTICE: Because of TrafficCalm’s commitment to continuous improvement the content of these documents and product specifications may change without notice. Please contact your partner or TrafficCalm Technical service to check for updates before planning your installation.

REVISION BLOCK

REV.	DESCRIPTION	DATE	Created By	APPROVED
A	Original Release	05/22/2014		
B	Product Name Change Only	05/11/2017	John H	
C	Push Button Activation Upgrade	08/07/2017	John H	
D	Lockswitch Upgrade	04/02/2019	Andy P	

*TraffiCalm Systems products
are built in an ISO9001
certified facility.*



ISO 9001

1 About this Manual

1.1 Purpose of Manual

This manual provides the installation and setup instructions for the TrafficCalm Portable 9” LED Driver Feedback Sign. This manual is intended for use by installers, maintenance personnel, and others who are responsible for the installation and maintenance of the driver feedback signs.

1.2 Manual Conventions

The conventions listed in Table 1-1 help to make this manual easier to use by presenting a uniform approach to the descriptions, phrases, and nomenclature.

1.3 Related Document

Other documents pertaining to Driver Feedback Signs (DFB) the supplemental installation guides for the solar and battery options not listed in this manual.

1.4 Manual Organization

This manual is divided into seven sections and two appendixes.

Section 1. About This Manual

Contains information about the organization and content of this manual.

Section 2. Safety Information

Contains important information about the safety messages, safety considerations, and procedures for installing this equipment.

Section 3. Description

Describes the driver feedback sign and related accessories.

Section 4. Installation Requirements

Describes the components, tools, and information you must have available before installing a DFB.

Section 5. Pre-Installation

Describes tests used to verify that all of the sign’s electrical components are functioning properly prior to installation.

Section 6. Installation

Describes system installation, startup, and operation for the 9” DFB.

Section 7. Troubleshooting

Contains general troubleshooting information for all DFB signs.

Appendix A. 9” DFB Drawing

Contains a drawing for the 18x24 inch driver feedback sign model.

Appendix B. Recommended External Beacon Wiring

Contains recommended external beacon wiring drawings.

Table 1-1. Manual Conventions

Element	Convention	Example
Acronyms	Uppercase	LED
Abbreviations	Lowercase ...except where standard Usage is uppercase	ms (milliseconds) Mb (megabits) MB (megabytes)
Model names	First or formal reference; initial caps	TrafficCalm 9” Driver Feedback Sign
	Subsequent use or informal reference:	Driver feedback sign, DFB or sign

2 Safety Information

We provide important safety information and warnings to assist you in understanding and avoiding potential harm to yourself, and possible damage to equipment during the installation of the Driver Feedback Sign. Although we have included many potential hazards you may encounter during the installation of this equipment, we cannot predict all of the possible hazards and this list should not be a substitute for your judgment and experience.

Please read and observe all safety information and instructions in this manual before installing the system equipment. Also, save this installation manual for future reference.

If you are unsure about any part of this installation or of the potential hazards discussed, please contact your supervisor immediately.

2.1 Intended Use

Driver feedback signs are intended to be used as a traffic calming tool, informing motorists of their actual speed in real-time.

2.2 Technical Support

If you have questions about the system, its use, or operation, please contact your local partner or call the TrafficCalm Technical Service department at 1-855-738-2722, in the U.S.A. Technical service hours: Monday through Thursday, 7:00 AM to 5:00 PM and Friday from 7:00 AM to 12:00 PM Pacific Standard Time.

2.3 Safety Messages

We include safety messages in this manual to help you protect your safety and the safety of others. This section contains important information to help you recognize and understand these safety messages.

Please read all messages before proceeding with the installation of this equipment.

2.3.1 Safety Message Format

Safety messages are designed to alert you to potential hazards that can cause personal injury to you or others. They can also indicate the possibility of property damage.

Each safety message box contains the safety alert symbol ; and one of three signal words:

DANGER, WARNING, or CAUTION; plus a safety message.

The signal words and symbols, and their meanings, are shown below:

 DANGER
The safety message is in this box.

DANGER indicates a potentially hazardous situation, which, if not avoided, will result in death or serious injury and/or property damage.

 WARNING
The safety message is in this box.

WARNING indicates a potentially hazardous situation, which, if not avoided, could result in death or serious injury and/or property damage.

 CAUTION
The safety message is in this box.

CAUTION indicates a potentially hazardous situation, which, if not avoided, may result in minor or moderate injury and/or property damage.

In addition to the symbols and words explained above, each safety message identifies the hazard, describes what you can and should do to avoid the risk of exposure to the hazard, and tells the probable consequences of not avoiding the hazard.

2.4 Safety Messages Contained in This Manual

The following safety messages appear in this manual:

 WARNING
To reduce the risk associated with electric shock injury resulting from contacting high-voltage AC. -Turn OFF power before connecting wiring to the AC source.

 **WARNING**

To reduce the risk of electric shock related injury resulting from contacting hazardous AC voltage:

- Portions of this equipment derive power from sources that have high voltage levels. These must be serviced by qualified personnel, who have previous training or certification to safely work on high voltage equipment.

Consult a Qualified Electrician.

 **WARNING**

Battery acid may cause skin irritation and eye injury. **To reduce the risk of burns or other acid related injury resulting from handling lead-acid batteries:**

- Wear gloves, goggles, and an apron when handling batteries**
- Beware of cracked battery cases**
- Handle batteries with care.**

 **WARNING**

To reduce the risk of burns or other acid-related injury resulting from exploding batteries:

- Always use the recommended charging systems with this product.**

 **WARNING**

To reduce the risk associated with contamination of water supplies resulting from improper disposal of batteries containing lead and acid:

- Please dispose of batteries in accordance with all local government laws and regulations.**

 **CAUTION**

Radar RF energy can be harmful to the eyes. **To reduce exposure to the risk of RF energy, do not stare into the radar antenna. Keep a minimum safe distance of 20cm (8-inches) from display face.**

IMPORTANT

Cleaning screen surfaces with solvents may damage the screening ink.

 **CAUTION**

An accidental short circuit may instantly heat conductive jewelry, tools, and surrounding objects to skin-searing temperatures. **To reduce this risk when working around batteries:**

- Keep tools, jewelry, and other conductive objects away from the battery terminals.**

 **WARNING**

To reduce the risk of impact hazards resulting from falls, accident with a passing vehicle, and/or from unstable equipment:

- Use appropriate work zone traffic control methods, equipment, and procedures.**

 **CAUTION**

Strain or back injury may result from lifting equipment improperly. **To reduce the risk of strain or back injury, use proper lifting techniques and have adequate help.**

 **CAUTION**

To avoid the possibility of injury due to falling or unstable equipment:

- Be certain the sign is mounted to an appropriately rated pole or equivalent mounting surface.**
- Use appropriately rated mounting hardware.**

2.5 Safety Considerations

Please consider the following safety issues before servicing TrafficCalm Driver Feedback Signs.

Although we have compiled this list of common safety considerations, it should not be considered as complete. It is not intended to take the place of your good judgment, training, and experience. Choose the right equipment for the job. If you are unsure of which safety equipment is recommended or appropriate for the job, ask your supervisor or foreman.

2.5.1 Personal Safety Equipment and Clothing

Personal safety equipment and clothing including high visibility vests, hard hats, gloves, electrical shock or electrocution protection clothing and equipment, safety shoes, safety glasses, face shields, goggles, and hearing protection devices are just some of the items available to you.

2.5.2 Electrical Shock

As a trained installer of electrical equipment you are aware of the dangers associated with servicing electrical devices. Always be sure that the power to the equipment, and all associated equipment, is turned off before beginning any procedure. Use the equipment, techniques, and procedures that you learned during your training or apprenticeship or other electrical industry recognized safety procedures.

WARNING

To reduce the risk associated with electric shock injury resulting from contacting high-voltage AC.

-Turn OFF power before connecting wiring to the AC source.

WARNING

To reduce the risk of electric shock related injury resulting from contacting hazardous AC voltage:

-Portions of this equipment derive power from sources that have high voltage levels. These must be serviced by qualified personnel, have previous training or certification to safely work on high voltage equipment.

Consult a Qualified Electrician.

2.5.3 RF Exposure

This product uses devices that radiate RF energy in the course of normal operation. Always maintain a safe working distance from the display face of 20cm (8-inches) minimum, when display is powered.

CAUTION

Radar RF energy can be harmful to the eyes. **To reduce exposure to the risk of RF energy, do not stare into the radar antenna. Keep a minimum safe distance of 20cm (8-inches) from display face.**

2.5.4 Battery Safety

WARNING

Batteries may produce an explosive gas under some conditions. This gas may easily be ignited by a spark or flame as you work near the battery. To reduce this risk of explosion:

-Disconnect the battery

-Work in a well-ventilated area

-Avoid the use of devices that create sparks or use open flames

-Use appropriate personal safety equipment and clothing

 **WARNING**

Battery acid may cause skin irritation and eye injury. **To reduce the risk of burns or other acid related injury resulting from handling lead-acid batteries:**

- Wear gloves, goggles, and an apron when handling batteries
- Beware of cracked battery cases
- Handle batteries with care.

 **WARNING**

To reduce the risk of burns or other acid-related injury resulting from exploding batteries:

- Always use the recommended charging systems with this product.

 **WARNING**

To reduce the risk associated with contamination of water supplies resulting from improper disposal of batteries containing lead and acid:

- Please dispose of batteries in accordance with all local government laws and regulations.

 **CAUTION**

An accidental short circuit may instantly heat conductive jewelry, tools, and surrounding objects to skin-searing temperatures. **To reduce this risk when working around batteries:**

- Keep tools, jewelry, and other conductive objects away from the battery terminals.

2.5.5 Mechanical Safety

 **WARNING**

To reduce the risk of impact hazards resulting from falls, accident with a passing vehicle, and/or from unstable equipment:

- Use appropriate work zone traffic control methods, equipment, and procedures.

 **CAUTION**

Strain or back injury may result from lifting equipment improperly. **To reduce the risk of strain or back injury, use proper lifting techniques and have adequate help.**

 **CAUTION**

To avoid the possibility of injury due to falling or unstable equipment:

- Be certain the sign is mounted to an appropriately rated pole or equivalent mounting surface.
- Use appropriately rated mounting hardware.

NOTICE

This equipment generates, uses, and can radiate radio frequency energy and, if not installed and used in accordance with the instruction manual, may cause harmful interference to radio communications. However, there is no guarantee that interference will not occur in a particular installation. If this equipment does cause harmful interference to radio or television reception, which can be determined by turning the equipment off or on, the user is encouraged to try to correct the interference by one or more of the following methods:

- **Reorient or relocate the receiving antenna.**
- **Increase the separation between the equipment and the receiver.**
- **Connect the equipment on an outlet separate from that to which the receiver is connected.**
- **Consult an experienced radio/TV technician for help.**

CAUTION: Changes or modifications not expressly approved by TrafficCalm could void the user's authority to operate the equipment!

MPH over the speed limit to further alert the driver of the speed violation.

Driver Feedback Signs present the driver with a highly visible display in the daytime or nighttime and under all weather conditions using high output LED's with photocell controlled automatic dimming. The automatic dimming provides the following benefits:

- Reduces power consumption and extends LED life.
- Prevents "blooming" at night.
- Provides excellent visibility in all conditions

The construction of the sign is modular with an environmentally protected electronics control system that mounts into the sign chassis (Figure 3-2).

The net effect is a driver feedback sign that is reliable and highly visible in all conditions. The Driver Feedback Sign in combination with a passive sign, which posts a regulatory speed, is an effective traffic calming tool designed to help reduce roadway speeds by enhancing a driver's speed awareness. Public safety is increased when roadway speeds are reduced.

2.5.6 Functional Safety

**WARNING**

The beacon outputs of this display should not be used as the only means to notify drivers of speed limit changes in school or work zones.

- Use an approved safety device or signage to notify drivers of traffic zone changes that may affect the safety of pedestrians, workers, or drivers.

3 Description

TrafficCalm Driver Feedback Signs offer an innovative traffic calming solution to vehicle speed management problems. The Driver Feedback Sign (Figure 3-1) is a fully self-contained, numeric sign. The sign's LED display provides "real-time speed" to drivers within the sign's radar detection zone. If the vehicle speed exceeds the programmed speed limit, LEDs will flash to alert the driver of the speed violation. The sign also has a programmable excessive speed threshold typically set to 5 to 10



Figure 3-1. Driver Feedback Sign



Figure 3-2. Easy Removal

3.1 9” DFB Sign Specifications

Electrical

- 12 VDC nominal
- 9 VDC minimum operating
- 30 VDC maximum operating
- 8.4 watts maximum power (100% traffic, sun on face of display)
- 5.5 watts typical during daylight (100% Traffic, bright sun)
- 2.1 watts typical during night (100% Traffic)

Operating Environment

Temperature range: -34°C to +74°C Ambient
 -29.2°F to +165.2°F

Humidity: 95% Non-condensing

Radar

- Frequency: K-band (24.125 GHz)
- Cone of View: 30 deg
- Detection range: approx. 400 ft (+400/-100)

Sign Size

- 18 inches wide
- 24 inches high
- 1.75 inches thick

Sign Weight

25 lbs

Communications

All LED DFB Models: Bluetooth Wireless Class 1

Configurable Parameters Using SafetyCalm™ Software

Speed Thresholds

- Minimum Display Speed
- Speed Limit
- Excessive Speed
- Maximum Display Speed

Display Modes

- Amber Speed Display
- Flash Amber Speed Display

Scheduled On/Off times

Data Collection

3.2 9” DFB Sign Power Options

The Portable Driver Feedback Sign has the following power options.

AC Charging Adapter

The AC Charging adapter is not approved for outdoor use, do not expose the adapter to rain, moisture, or other dangers that may risk damage to the charger and/or sign. It is recommended that the sign be allowed to charge overnight; charge time from empty will take approx. 6 hours. The AC adapter is designed to optimize battery capacity and charging; it will not overcharge and prevents damage to the internal battery. The included adapter is intended for use with the sign it is supplied with, do not use to charge a 12” portable display; this may will not fully charge the display. Conversely, a charge adapter intended for use on a 12” sign will cause damage to the battery in a 9” sign.

The charger plug is internally fused to prevent a catastrophic failure of the battery harness in the event the plug is shorted.

Table 3-1. AC Charging Adapter Specification

Dimensions (Inches) Width, Height, Depth	8,8,6
Weight (lbs/kgs)	12, 5.5
Input Voltage (VAC)	100 - 120
Nominal Output Voltage (VDC)	18.5
Output Rated Current (Amps)	3.2

Table 3-2. Internal Battery Specification

Type	NiMH
20 Hr Rate (AH)	20

4 Installation Requirements

This section describes the components, tools, and information you must have available before installing TrafficCalm’s 9” Driver Feedback Sign.

4.1 Equipment Requirements

In addition to the Driver Feedback Sign to be installed, you will need the following items:

Connection wire that meets applicable electrical codes and any standards established at the installation site.

Typical AC hard wired installations will require a power cut-off switch that will open all energized conductors that is in clear sight of the sign.

A laptop PC with wireless Bluetooth is required to operate the DFB software to configure the sign.

Installation Requirements for Sign Power Modules

- **AC Installation:**
Check the installation site for an existing power source that can supply continuous AC power to the driver feedback sign. If your site does not have power facilities, new power lines must be routed to the sign or a different installation site will be required that has power.
- **Solar Kit Installation:**
Check the installation site for a clear view of the sky for the solar panels. It is particularly critical that the solar panels have a clear view to the south at the angle of the sun in the winter time. If your site does not have a clear view of the sky, a different installation site must be selected that has a clear view of the sky.
- **Battery Charger Kit Installation:**
Check the installation site for an existing lighting power source that can supply AC power to the driver feedback sign at night. Determine the voltage that the street lighting is operating on and verify that the correct battery charger kit has been selected.

4.2 Requirements for SafetyCalm™ Software

TrafficCalm's Driver Feedback Sign Software is a configuration, diagnostic, communication, and speed data tool intended for use with Driver Feedback Signs. All TrafficCalm Driver Feedback Signs are equipped with wireless Bluetooth Class 1 communication.

Minimum Laptop PC System Requirements

Windows XP, Vista, or 7 operating system

Microsoft® Internet Explorer 5.0 or greater

Bluetooth wireless communication

CD-ROM drive for installation

5 Pre-Installation

The 9" Driver Feedback Sign should be installed on roadway sections that provide the most benefit to the public. Once an installation site has been selected, it should be verified with a site survey.

Also, prior to installation, the sign should be tested to verify that the sign's electrical components are functioning properly and that the sign was not damaged during shipping.

If any of the tests performed fail, refer to the troubleshooting section of this manual to diagnose the problem.

5.1 Site Survey

Before installing the Driver Feedback Sign, an installation site must be selected. It is very important to select a site with the following characteristics:

There must be a clear view of the sign from the roadway for at least 500 feet and, the viewing area must be clear of trees. Attenuation of the radar's signal, caused by trees, may reduce the radar's effective range.

Do not install the sign facing an intersection or bridge if possible. If the sign must be installed facing an intersection or bridge, the sign should be located at least 400 feet away. Cross-traffic may be registered by the radar as an oncoming vehicle.

The sign should be located at least 200 feet away from large street signs that fall within the radar's detection zone and cause the radar to reflect its' output. Reflecting the radar's output by objects such as signs may cause vehicles to be detected in the opposite direction.

Install sign in roadway geometries that allow clear view of the sign's display and provide the most efficient radar detection zone.

Proper site selection will provide the greatest traffic calming effect and sign performance.

5.2 Pole Selection

Pole selection for the Driver Feedback Sign is an important element in the installation design. Poles selected for mounting the DFB must support the weight and wind loading of the sign, power option and any static signs. Crash worthiness may also need to be considered. Use a break-away pole and attach the display using a 3 point bolt structure to improve crash worthiness.

Based on a wind load of 29 pounds per square foot, the sign wind load is 87 pounds. Based on an ice load of 3 pounds per square foot on all surfaces and dead load the max sign weight is 37 pounds. This is based on a max wind of 90 mph with an exposure category of C reference the International Building Code. For different wind and ice conditions, consult a local engineer. Supply mounting hardware and poles adequate for the loads. If using bands, do not over-tension.

After a storm approaching or exceeding 90 mph winds, inspect the sign and mounting for damage and replace or repair as required.

In mounting the sign use a minimum of 2 bands centered on the back mounting bracket or a minimum of 3 each, 3/8” bolts with flat washers and other mounting hardware as required.

5.3 Mounting Bracket

The 9” Driver Feedback Signs are provided with mounting provision at the back of the sign. The mounting provision is designed to be banded and/or anchored/bolted to the mounting structure. Anchoring and bolting is recommended over banding to improve performance in areas where high wind is normally expected and for increased crash integrity capability. Listed below is some additional mounting hardware that may be used to mount the sign to a pole:

Preferred method:

- Pelco Bands, P/N: US-8124-06
- Pelco Banding Buckles, P/N: US-8124-56
- Tools Needed: Pelco P/N: US-8120-01 and US-8120-06 handle.

Another option is the EZ-Band Kit P/N US-8500 (one per band) with US-8122-06 banding, or US-8504 with US-8124-62 banding. Standard tools can be used to tension these; however they are not as secure since standard tools can also remove them.

- Pelco can be contacted at 1 (405) 340-3434 for product and ordering information.

5.4 Sign Test Procedure

Connect the sign to the appropriate power source. Verify that the display and display controller are functioning correctly.

Using the DFB software place the sign in test mode.

The sign then cycles through its test character set until the sign is taken out of test mode using the DFB software.

Visually verify display functionality. If the sign fails, refer to the Troubleshooting section of this manual for help.

Verify that RADAR mode is functioning correctly. Using the SafetyCalm™ software, set the display status to on. The sign enters its normal mode of operation. Note: The factory setting powers up with the radar on.

Place the sign in a location where vehicles are approaching the sign within the range of the radar.

Visually verify that the sign is displaying a speed value approximately equal to that of the approaching vehicles.

5.4.1 Expected Sign Behavior

The table below (Table 5-1) details the expected operation behavior of a DFB’s scheduled ON/OFF states. SPEED represents the state where a DFB is measuring and displaying vehicle speeds. BLANK represents the state where no vehicles are approaching the sign or the sign is in the scheduled OFF state.

Table 5-1. DFB Operation Behavior

SCHEDULE STATUS	Vehicle Present	No Vehicle Present
ACTIVE	SPEED	BLANK
OFF	BLANK	BLANK
EXPIRED	BLANK	BLANK
No schedule and Display OFF	BLANK	BLANK
No schedule and Display ON	SPEED	BLANK

6 Installation

This section contains installation procedures for a Driver Feedback Sign (DFB). The DFB requires 12 VDC power to operate the sign. Depending on the power option selected to provide the 12 VDC, the signs can be powered by continuous AC power, a solar kit, street lighting power, or simply by batteries only that must be recharged periodically.

6.1 Sign Installation

Attach the mounting bracket to a suitable pole or structure.

The bottom of the sign should be about 7 feet above the ground as shown in Figure 6-1. Aim and band or bolt the sign to the pole.

Assemble the DFB sign (A) to mounting bracket (B) as shown in Figure 6-2.

Figure 6-1. Typical DFB Mounting



Figure 6-2. Connecting DFB Sign to Bracket

6.1.1 Aiming the Sign

The 9" DFB contains an internally mounted radar speed detector to detect on-coming vehicle speed. The radar requires that the face of this sign be aimed, allowing the radar to accurately detect vehicles. For best operation, the face of the sign should point into traffic as close to parallel with the direction of traffic flow as possible. For best accuracy, the angle of incidence should be 5 degrees or less. Angles of incidence greater than 10 degrees will display slower than actual vehicle speed. For best range try not to aim the sign so that the lanes of receding traffic are in the radar detection area.

6.1.2 Sign Radar Operation

The sign's radar continually emits weak levels of microwave energy at a specific frequency (K-band, 24.15 GHz) and scans for returns from moving objects. When this microwave energy encounters an object, some of the energy is reflected back to the radar. If the object is moving, the frequency of the reflected microwaves is changed by an amount proportional to the relative speed of the moving object. This characteristic frequency change is known as "Doppler Effect." The radar unit measures the difference between the frequency of transmitted energy and the frequency of the reflected energy to determine the relative velocity of the moving object.

Ensure that the following items are taken into consideration when choosing an installation site for the sign:

The sign may display speeds of vehicles traveling perpendicular to the sign's face. Ensure that the sign is not installed within 400 feet of an intersection, bridge, or similar roadway feature.

Obstructions such as a static sign, building, inclination, or similar factors may influence the distance range of the vehicle detection and the accuracy of the displayed speed values.

The radar needs to have a clear view of the targeted vehicles. Avoid mounting the sign behind trees, poles, tall parked vehicles, and so on.

The system should not be used in the range of road turns and bends. This may result in the sign displaying speeds that are lower than the actual speed of the object.

6.1.3 Radar Properties

The distance range of all microwave detectors depends to a large extent on reflection properties of the measured objects and interference properties of the nearby surrounding objects.

The following properties can be expected:

Vehicles that appear larger and flatter to the microwave beam axis provide a longer radar detection range.

A less absorbing and scattering reflective surface results in a longer detection range.

As more objects obscure the radar measurement beam, the detection zone will become shorter (diffraction scattering, foliage losses, shadow losses, and so on).

The following factors have a reducing effect on the distance range:

Buildings, trees, poles, parked cars and containers, which hamper the "free sight" of the radar detector and may lead to shorter ranges.

Influence by weather, rain and snow lead to absorption losses at the radar detector.

"Blinding of the Radar" by stationary traffic in the radar beam, or extraneous moving objects like branches of trees, birds and so on.

Depending upon vehicle type and reflective properties, the typical passenger car will have a

detection range of 400 feet for the 9" DFB. For trucks, the distance range is about 50% to 100% longer due to the larger reflective surface. For motorcycles, distance range is reduced by 50%.

The above mentioned detection distance limits are not a limitation of the radar itself, but the optimal viewing distance of the driver. We reduced the radar's detection range so that the driver can view his/her speed clearly while approaching the sign. The optimum distance range has a sign mounted at a height of 7 feet from grade to the sign's housing bottom.

6.1.4 Measurement Angle

The angle between detector beam axis and the movement axis of the detected vehicle (see Figure 6-3) has direct impact on the measured speed. This is expressed by following formula:

$$V_{\text{measure}} = V_{\text{absolute}} \times \cos \phi$$

with ϕ : measuring angle

The ideal measurement angle is 0° , this means $V_{\text{measure}} = V_{\text{absolute}}$ and movement axis and radar beam axis are identical in this case.

IMPORTANT

The error in the speed values will become greater as the measurement angle increases.

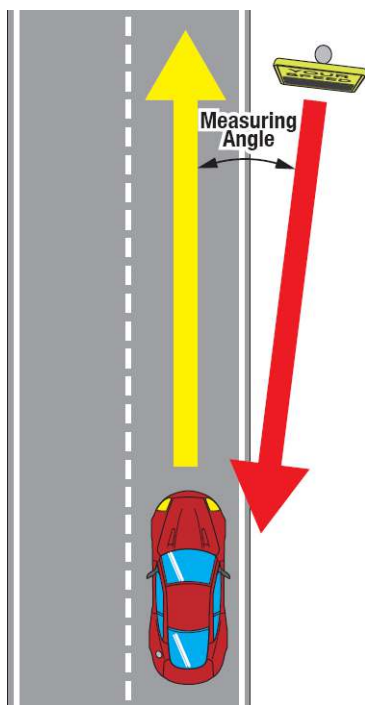

Figure 6-3. Radar Speed Errors

6.1.5 Powering and Charging Instructions

Applying Power to Sign:

1. Make sure the AC charging adapter is disconnected from the display.
2. Turn keyed On/Off switch on back of sign
3. The sign will power up in Radar mode, ready for installation.
4. Test the function of the sign to ensure proper field operation.

Charging the sign

1. Turn Sign Off using the keyed ON/OFF switch on back of sign
2. Remove Sign from pole mount bracket.
3. Plug AC Charger into Battery Charge Port on back of Sign.
4. Charging will be completed when charging indicator light turns off

See Figure 6.1.5

Applying Power to Sign:

Figure 6.1.5

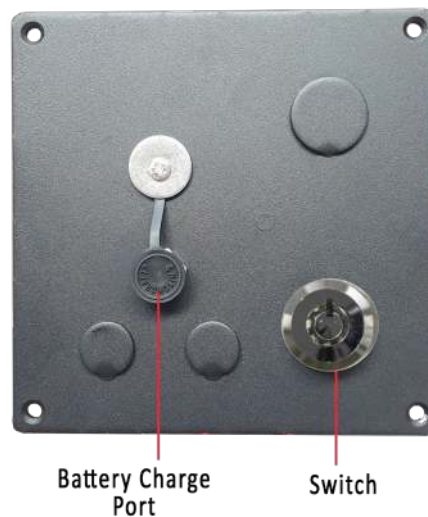

6.1.6 External Beacon Connection

TraffiCalm LED Driver Feedback Signs have provisions to connect external beacons that can be controlled by sign functions. The connections are made with a six pin connector located on the bottom of the ECS under the access panel.

The external Beacon connector has the following pin assignments. Connect as shown in Figure 6.5.

- Pin 1 Fused (1A) 12VDC output from the Display DC input
- Pin 2 Opto-Isolator Positive common
- Pin 3 Beacon DC control #1 (provides DC Return when active)

- Pin 4 Beacon DC control #2 (provides DC Return when active)
- Pin 5 Beacon Output DC COMMON (Fused at 1A)
- Pin 6 Display Common

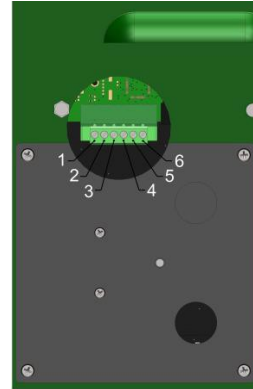

Typically you would either provide field (beacon) power to position 2 (+) and common to 5 (-), or jumper 1-2 and 5-6 if no isolation is needed to draw power off of the display batteries. In either case, the beacons are wired to the positive source and the display outputs provide the DC Common path. The outputs are rated for up to 60V standoff and ½ Amp of current.

Default behavior (Control Mode):

- Output #1 (pin 3) is goes active when a vehicle speed crosses above the over limit setting.
- Output #2 (pin 4) is active whenever the display is in RADAR mode.

The beacon outputs can be programmed with the DFB software for two other modes of operation.

- Beacon mode 1 causes the beacon control outputs (pins 3 and 4) to activate alternately at a 1 Hz rate when the sign is active in radar mode.
- Beacon mode 2 causes the beacon control outputs (pins 3 and 4) to activate alternately at a 1 Hz rate when a selected sign speed threshold is exceeded.

See drawings in Appendix B for recommended beacon wiring.

⚠ WARNING
The beacon outputs of this display should not be

6.1.9 NiMH Battery Storage

NiMH batteries can give safe and reliable service if they are used in accordance with recommended procedures and are not abused. Trafficalm Systems advises the following steps to care for both your DFB sign and battery pack.

DFB Sign / Battery Storage Recommendations

The DFB sign and battery pack should be kept clean, dry, and in a temperature range of -20 C to +35 C while in storage. The provided charger is not a battery maintainer and the internal charging systems of the DFB sign are not designed to “maintain” the battery. Before storing the sign, the battery should be charged for approximately 10 hours. After the charging is complete, unplug the charger and store the sign. If the sign is to remain in storage for 30 days or longer it is recommended to connect the supplied charger to a 24-hour mechanical timer (Coleman Cables LLC # 50001 or equivalent) programmed to be ON for 2 hours and OFF for 22 hours.

Charging Method and Considerations

The NiMH composition of the battery is subject to self-discharge. To ensure maximum performance before deploying the DFB sign to a location, the battery should be charged for at least 10 hours prior to use. To ensure a proper charge, plug the AC Charger into the sign; ensure the charger is screwed into the Battery Charge Port located on the back of the sign, for positive connection. (See Figure 6.1.5)

Long Term Handling

In order to ensure maximum performance of the battery pack over its life, the battery should not be stored for a prolonged period while connected to a load. If the battery has been stored for an extended period of time charge capacity may be reduced. The capacity may be recovered within two or three charge / discharge cycles.

7 Troubleshooting

This section provides troubleshooting information intended for use by technicians who are familiar with this type of variable message sign. The right knowledge combined with a systematic approach to the problem will result in an efficient and timely repair. Once the problem is identified, analyze why the failure occurred. If a maintenance issue led to the failure, include it in the next preventive maintenance trip to all of the signs. If a fuse blew, find out why instead of just replacing fuse after fuse. One small problem may be an indication of a larger problem about to happen. Fix problems before they happen whenever you can.

To use this guide, start at the beginning of the troubleshooting table (see Section 7.1). Each observation listed in the table describes a basic problem that a user might encounter and suggests a course of action. In some cases, the course of action is to look at another section of the table. The situations start out general and get more detailed as progress is made. Once a description of the problem is found that most closely matches what you observe, follow it to its logical conclusion in the “Cause/Action” table.

The first step in troubleshooting is to clearly define the problem. Here are just a few examples:

Is the problem intermittent or continuous?

Is the problem present only in the operation mode or, does it also occur in the test mode?

If needed, technical assistance is available by contacting your local partner or TrafficCalm Technical Service department at 1-855-738-2722.

Technical service hours: 7:00 A.M. – 5:00 P.M. Pacific Standard Time, Monday through Thursday and 7:00AM to 12:00PM PST on Friday.

7.1 General Troubleshooting

Observation	Possible Causes	Solutions/Action	Reference
Sign is non-functional – Can't connect with Bluetooth	No power to Sign	Check power (Look behind front face through masked segment openings to see if any red lights are on) - Restore Power to Sign	See Section 6
	Sign has Shut down and is sleeping due to very low voltage	Check voltage to sign – Diagnostic Red LED's may be lit or may flash periodically. Volts applied to sign less than 10.5V - Restore proper voltage to the sign.	See Section 6
	Sign is configured OFF, Bluetooth module bad	Cycle power to the display and check for Bluetooth activity. Immediately connect and disable schedules until configuration can be fixed (remove Bluetooth OFF command from schedule). If Bluetooth module never responds the sign must be replaced.	
	Sign is configured to be OFF, PC Bluetooth device is bad. (See also "Cannot communicate to sign")	Test the PC Bluetooth device function using known good Bluetooth equipped devices. Check Bluetooth setup (configure for serial connection)	
Sign is non-functional – Connection with Bluetooth is possible	Sign scheduled OFF or incorrect schedule	Using SafetyCalm™ software, schedule the sign ON or select a configuration that is "ON".	See the <i>SafetyCalm™ Software online help</i>
	Display disabled	Verify that sign is supposed to be enabled. Enable the display using SafetyCalm™ software.	See the <i>SafetyCalm™ Software online help</i>
	Sign has shut down due to temperature or low voltage (Not Sleeping)	Use SafetyCalm™ software to check internal sign temperature or applied voltage. Operating temperature: -50°C < Sign < +80°C Operating Voltage: 11.0V < Sign < 30V Sign will resume operation when conditions return to normal levels.	See Solar Kit Manual See Battery Charger Kit Manual See AC Power Kit Manual
	Failed Electronic Control System	Verify Sign has proper voltage and current available. Verify sign is properly configured (and scheduled*) with SafetyCalm™ software. Verify that sign has proper temperature. Replace sign if needed. *Schedules are not necessary to make the sign run, but they can prevent it from running.	See SafetyCalm™ Software manual

iQ900 Portable Driver Feedback Sign Installation Instructions

Cannot communicate with the sign	No power to sign	Check power connection to sign and verify operation.	See Section 6
	Bluetooth device on PC is disabled or missing.	Check the status of the Bluetooth device on the PC. Enable the device or reset the driver as needed.	See the <i>SafetyCalm™ Software online help</i>
	Bluetooth Software Parameters are not properly setup	Using the Windows Bluetooth wizard, reconfigure the communications parameters to match the sign parameters. Configure link for Serial Connection.	See the <i>SafetyCalm™ Software online help</i>
	Display is out of range.	Move the PC or Bluetooth module closer and in front of the display.	See Section 6.
The sign is not detecting cars as expected	Sign is not aimed properly	Re-aim the sign while taking into account a 30 degree radar beam width to cover the approaching lane of travel at the required distance.	See Section 6.1.1
		Re-aim the radar beam width for least spill-over into the opposing lane of travel.	
	The radar signal is being reflected	Ensure that there are no large static signs or other obstructions within 200 feet of the sign face.	See Section 6.1.1 for aiming and Section 5 for pre-installation requirements
	Sign speed settings are interfering	Double check sign configuration matches expected behavior.	
	Low Range: Squelch adjustment too high Phantom targets: Squelch adjustment too low	Readjust Squelch to get desired noise rejection and range.	See the <i>SafetyCalm™ Software online help</i>
	Other Hardware Malfunction	Contact Technical Service at 855-738-2722	
The sign is displaying speeds of vehicles traveling away from the sign	The radar signal is being reflected in a way that causes the sign to register the speed of vehicles traveling away from the sign	Ensure that there are no large static signs or other obstructions within 200 feet of the sign face. These objects can reflect the radar signal, causing the sign to register the speed of vehicles traveling away from the sign.	See Section 5 for pre-installation requirements
	Long range signal to noise ratio too low.	Weak signal targets at limit of range may not resolve direction properly causing display hold time to show the speed of a misread target. Adjust Squelch higher to reject weaker signals or adjust aim of display to strengthen signal or reduce noise.	
	Display malfunction	Contact technical service at (855) 738-2722.	
The sign is displaying unexpected speeds of oncoming vehicles near an intersection	The radar signal is measuring cross traffic	Cross traffic can register as oncoming vehicles to the radar. Ensure that the sign is located at least 400 feet from an intersection Adjust “Squelch” to suppress noise from cross traffic and reflections.	See Section 5 for pre-installation requirements
Display has no power	AC Supply: Service Power Failure	Restore service power	

	<p>AC Supply: Service okay, no AC/DC supply output</p>	<p>Check disconnect switch setting : set to ON</p> <p>Check output of AC/DC supply device in power supply box.</p> <p>Make sure the AC/DC supply outputs 12VDC at required load, and replace if not.</p>	
	<p>Solar Power: Fuse opened</p>	<p>Check display, connectors and wiring for damage or other short circuits, then replace fuse with same type and rating.</p>	
	<p>Solar Power: Low battery</p>	<p>Too much load for available power: reschedule the display operating times, display brightness, etc. to conform to available sunlight.</p> <p>Solar Charger Failure: Test for proper operation and replace if needed (see device operator manual from manufacturer)</p> <p>Solar Panel Failure : Clean off solar panels, check orientation and angle, check for damage and replace if needed</p> <p>Battery Failure due to age, temperature, or abuse: Replace Batteries after fixing abusive conditions.</p>	
	<p>Solar Power: Solar Charger failure</p>	<p>Charger is not charging batteries: If panel voltage is 20V and battery voltage is less than 12.7V then replace charger.</p> <p>Charger is not providing output to load: If battery is greater than 12.7V and no load output then replace charger.</p>	
	<p>Battery Charger Kit: Fuse Opened</p>	<p>Check wiring, connectors and display for damage that may cause short circuit, then replace fuse with same type and rating.</p>	
	<p>Battery Charger Kit: Low battery</p>	<p>Source power missing too long: The source may switch on and off automatically but must return every other day for 8 hours minimum.</p> <p>Charger has failed. Check charger operation and replace if needed.</p> <p>Cabinet over temperature: Check for proper ventilation, fan operation and no external heat sources.</p> <p>Transformer failure: Check transformer tap settings and wiring, and proper operation and no load to full load voltage drop (keep less than 5%).</p> <p>Battery failure due to age, temperature or abusive conditions: Replace Batteries after fixing abusive conditions.</p>	
	<p>All types: Bad connection to display</p>	<p>Check connections between display and power source and repair as needed.</p>	



TrafficCalm Systems provides the following warranty for its traffic calming solutions whether sold directly by TrafficCalm or by an authorized TrafficCalm distribution partner.

Warranty

- TrafficCalm Systems warrants the product, excluding batteries, will be free of defect in materials and workmanship for a period of three (3) years beginning on the day the end user receives the product. Warranty is only valid if the product is ineffective for its intended purpose due to defects in materials or workmanship.
- Warranty is only valid if the product is installed, operated and maintained in accordance with the manufacturer's instructions and recommendations (available upon request).
- TrafficCalm's sole responsibility, and the purchaser's and users' exclusive remedy, shall be that TrafficCalm will furnish replacements for defective parts.
- Replacement parts will carry the unexpired warranty of the parts they replace. Non warranty repairs are guaranteed for a period of 90 days.
- Claims made under this warranty will be honored only if TrafficCalm is notified of a failure within the warranty period, reasonable information requested by TrafficCalm is provided, and TrafficCalm is permitted to verify the cause of the failure.
- TrafficCalm assumes no liability for any incidental or consequential damages, in any way related to the product regardless of the legal theory on which the claim is based.

This warranty does not cover damage resulting from:

- Accidents, vandalism, impact with a foreign object, or acts of God.
- Product modifications made by someone not authorized by TrafficCalm
- Failure of Customer to follow TrafficCalm's published operating instructions,
- Failure to follow TrafficCalm's published site selection and installation instructions,
- Removal or relocation of the unit,
- Electrical work external to the unit, virus/hacker activity, and external computer errors.

THIS WARRANTY IS MADE IN LIEU OF ALL OTHER WARRANTIES AND CONDITIONS, EXPRESS OR IMPLIED, INCLUDING BUT NOT LIMITED TO THE IMPLIED WARRANTIES AND CONDITIONS OF MERCHANTABILITY.

Appendix A: 9" DFB Drawing

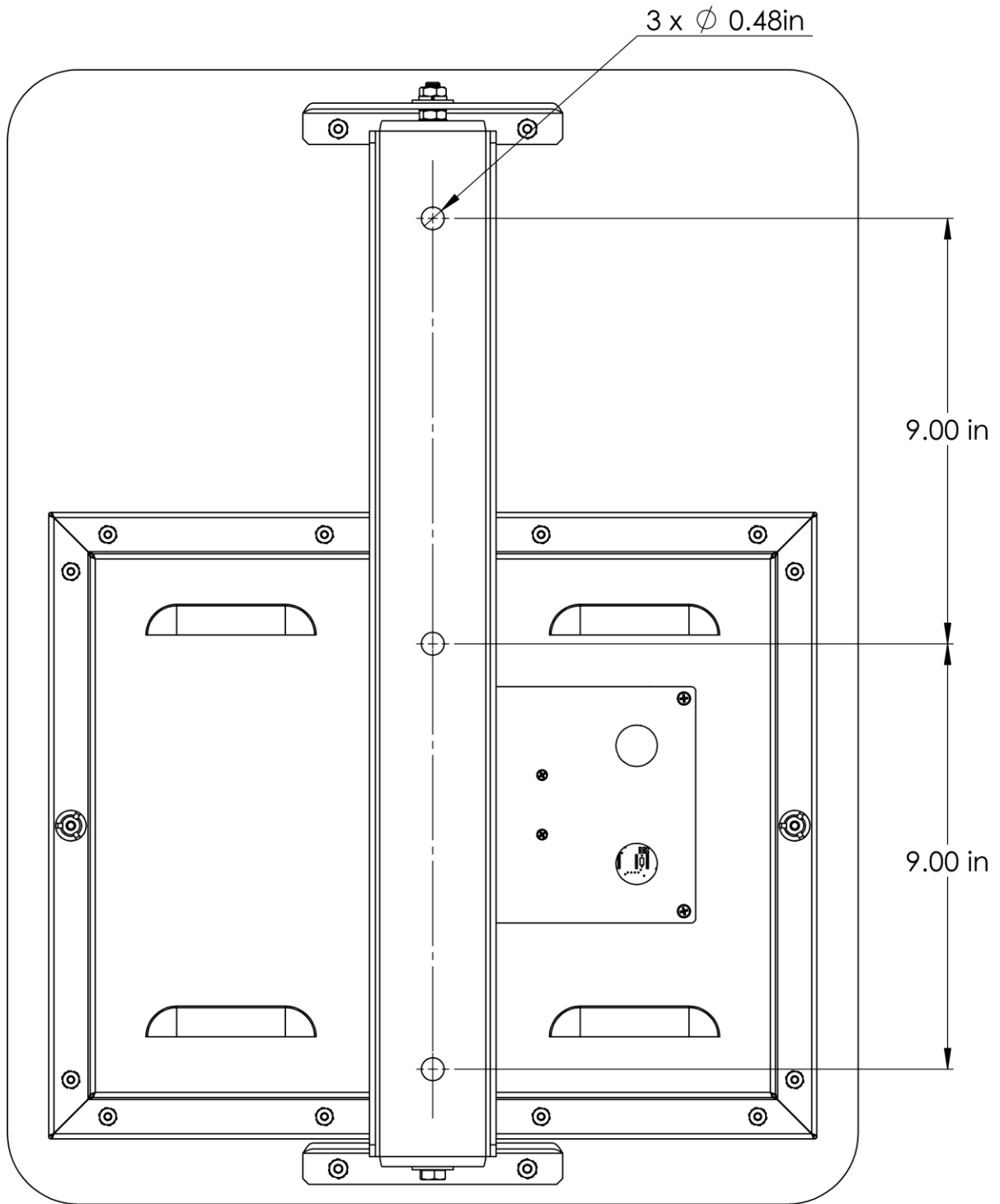

BACK OF SIGN
SIGN MOUNTING HOLE PATTERN

Appendix B: Recommended External Beacon Wiring

Note: Connector order is with respect to facing front of upright display.

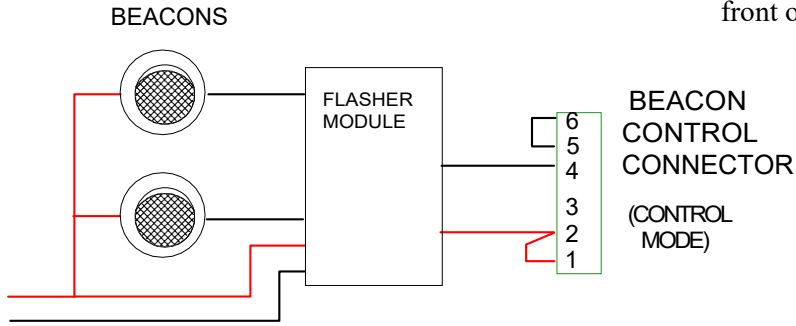

**RECOMMENDED WIRING
BEACONS 25W OR MOR, OR AC POWER
EXTERNAL FLASHER TIMING**

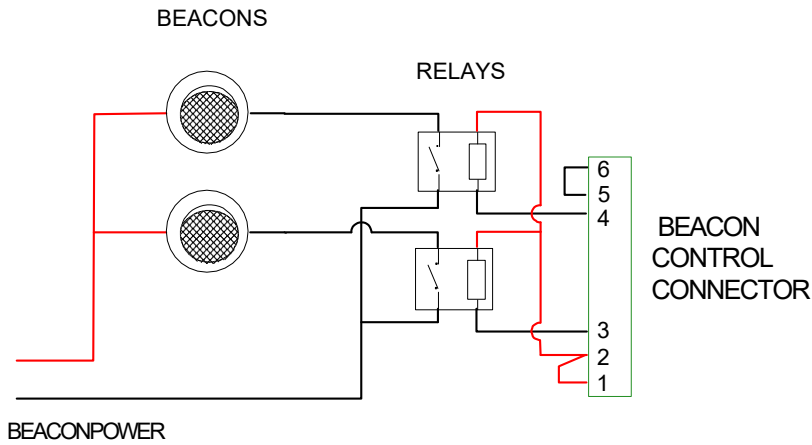

**RECOMMENDED WIRING
25W OR MORE, OR AC POWER
DISPLAY BEACON TIMING**

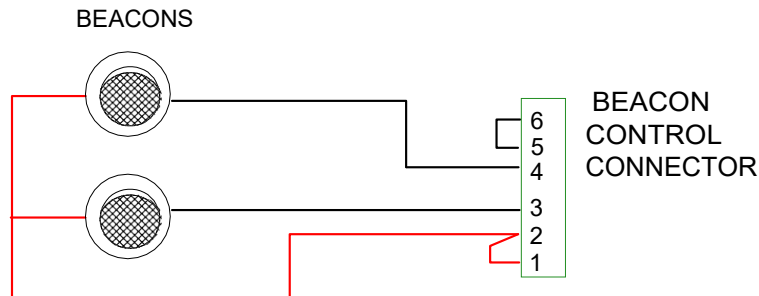

**RECOMMENDED WIRING
BEACONS 12W or LESS, 12VDC
DISPLAY BEACON TIMING**